

Аксонетрическая проекция

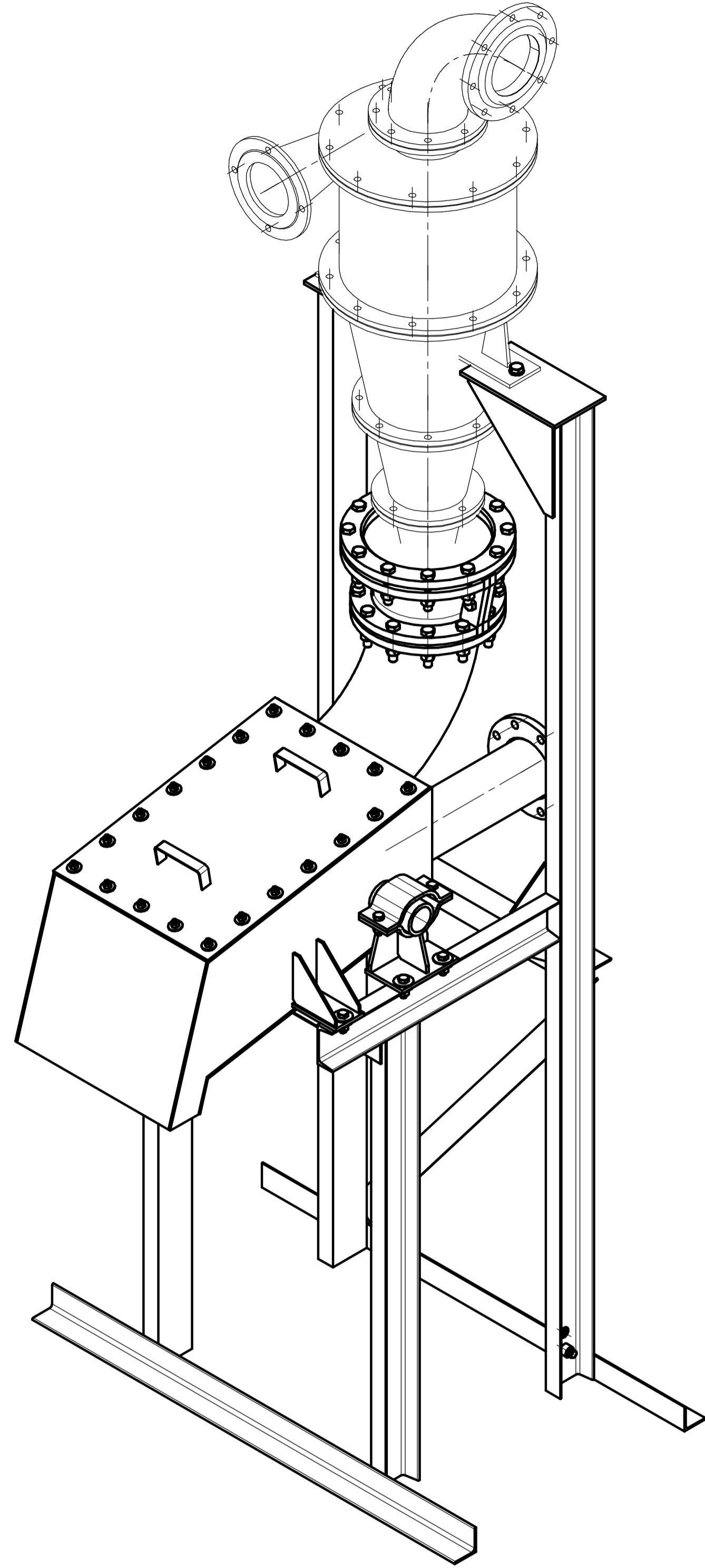

Э (1:2,5)(5В)
До механической обработки

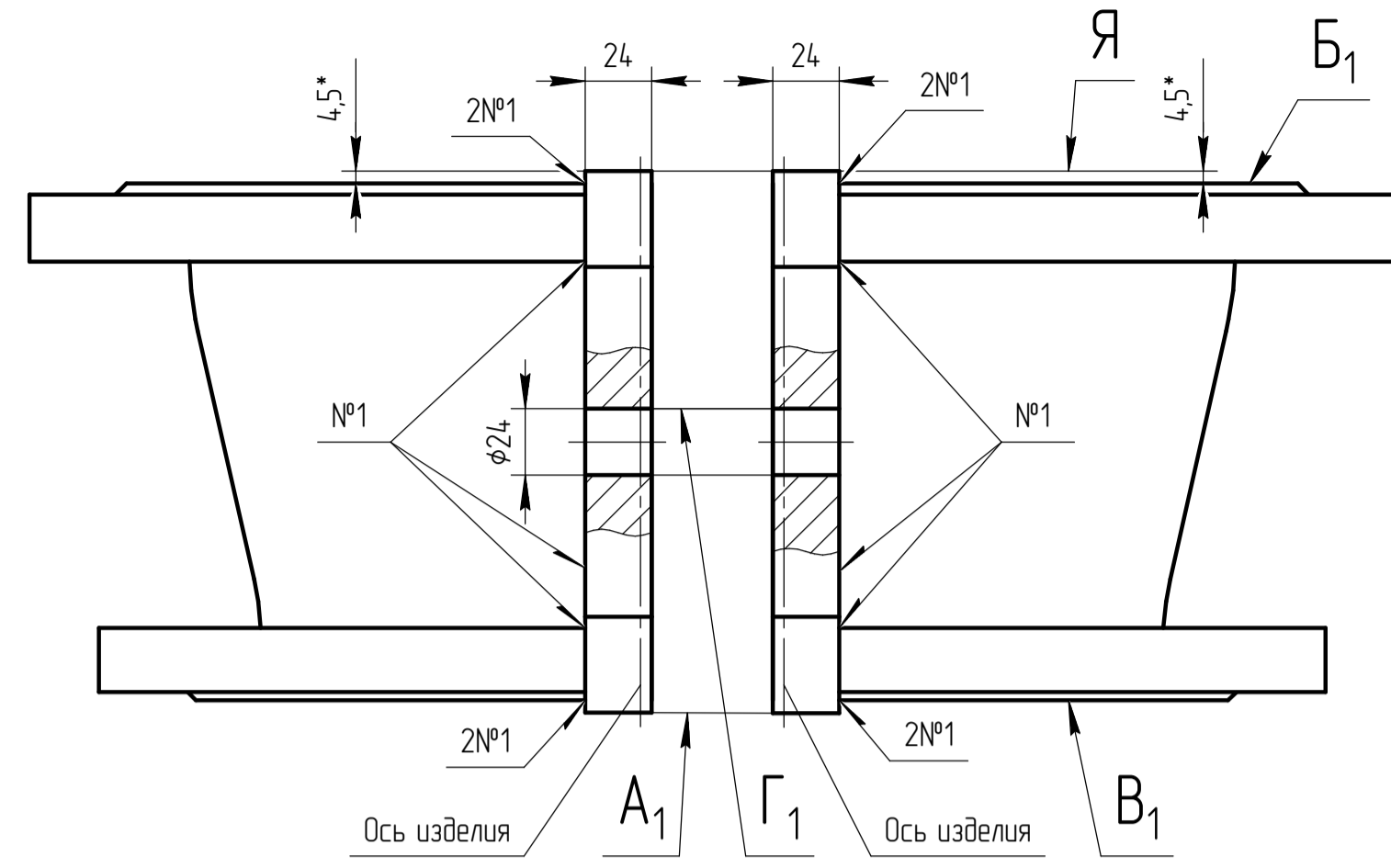

Е-Е(1:2,5)(4В)
До механической обработки

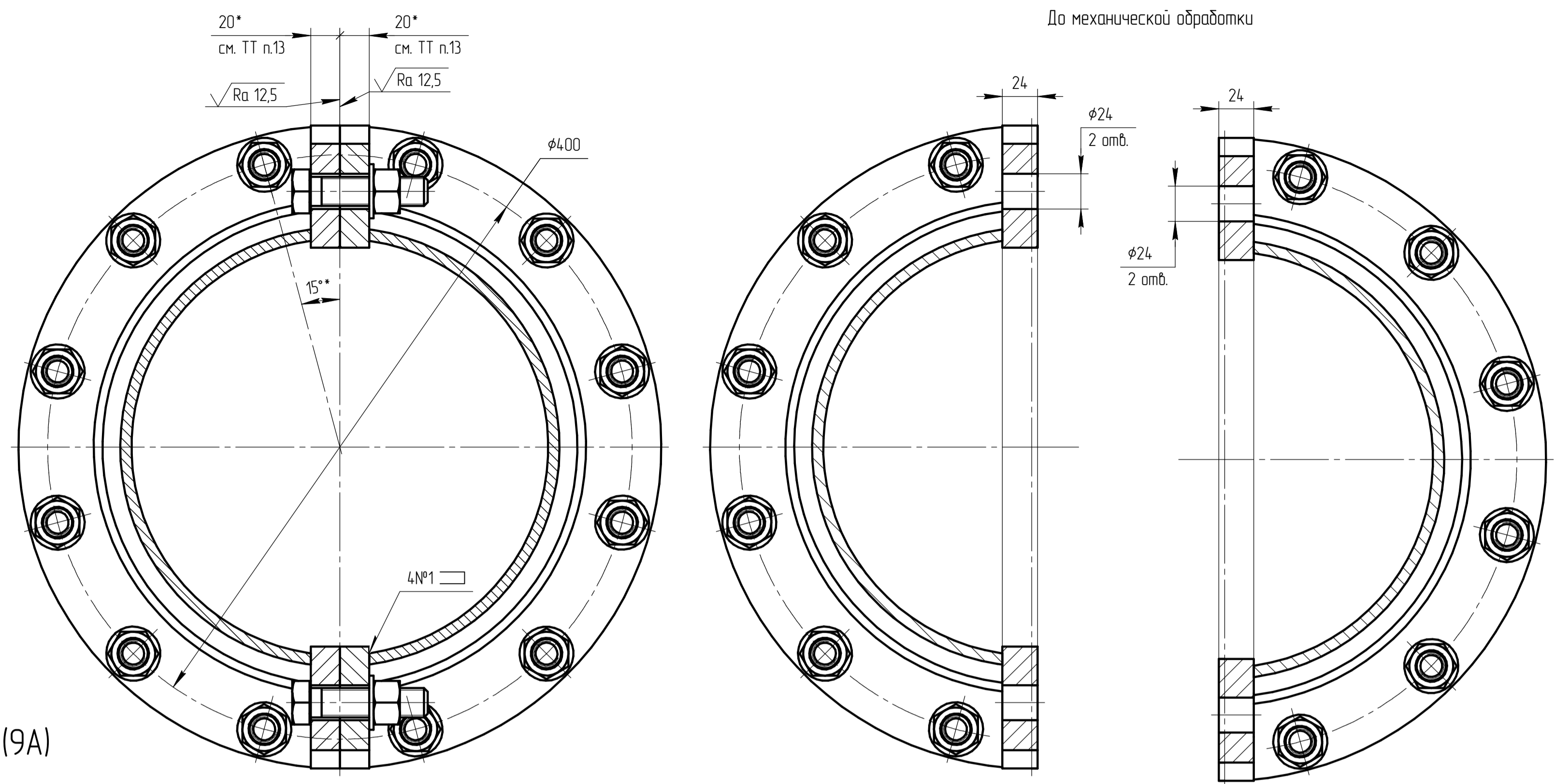

Л-Л(8В)

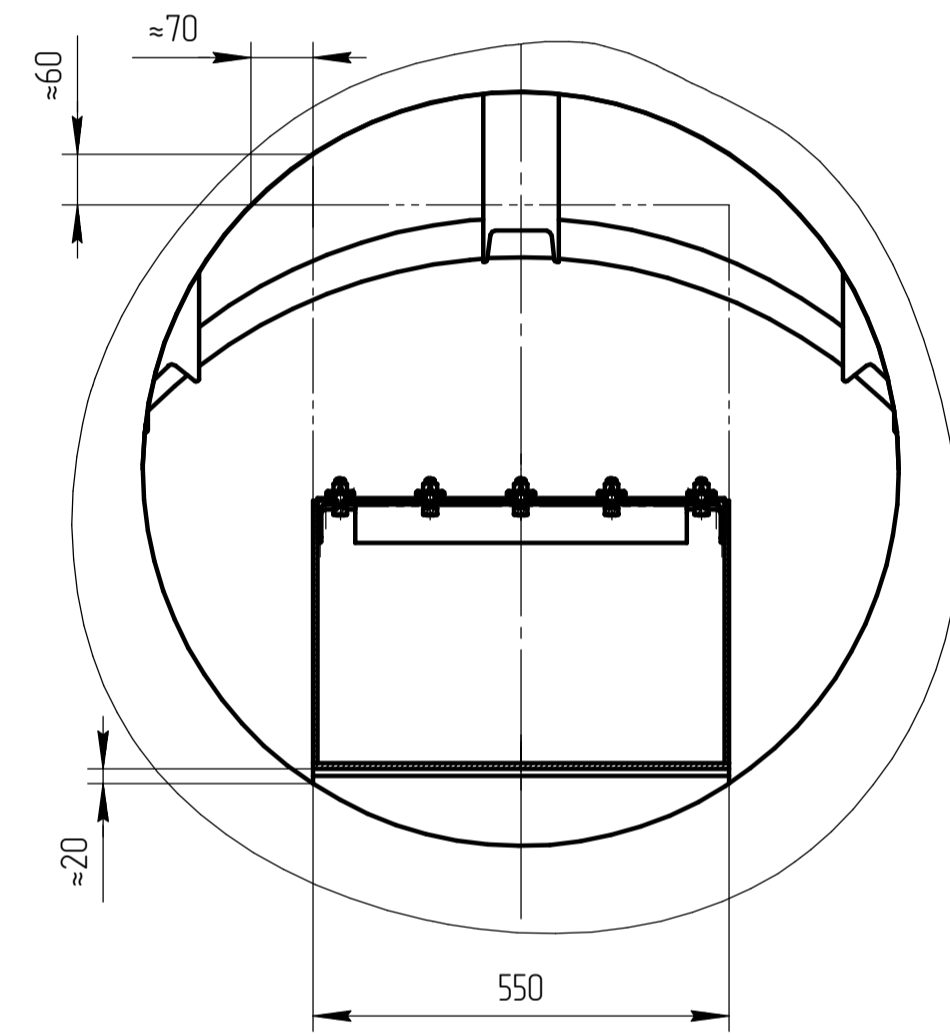

П-П(1:2)(9А)

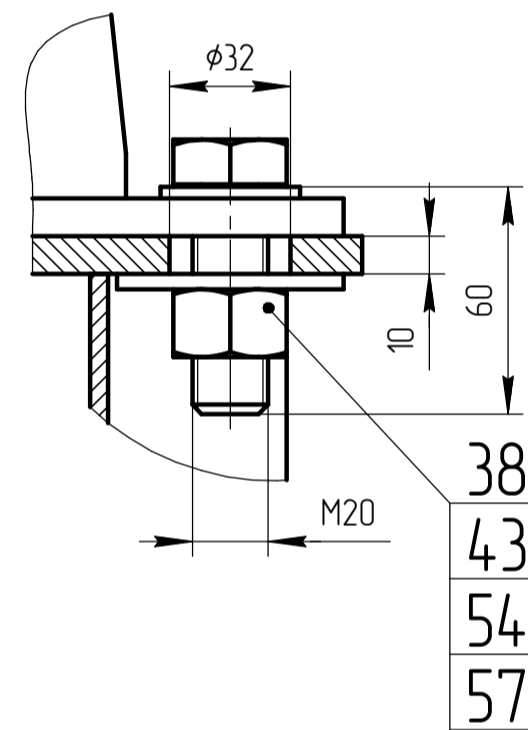

Ц-Ц(1:5)(5В)

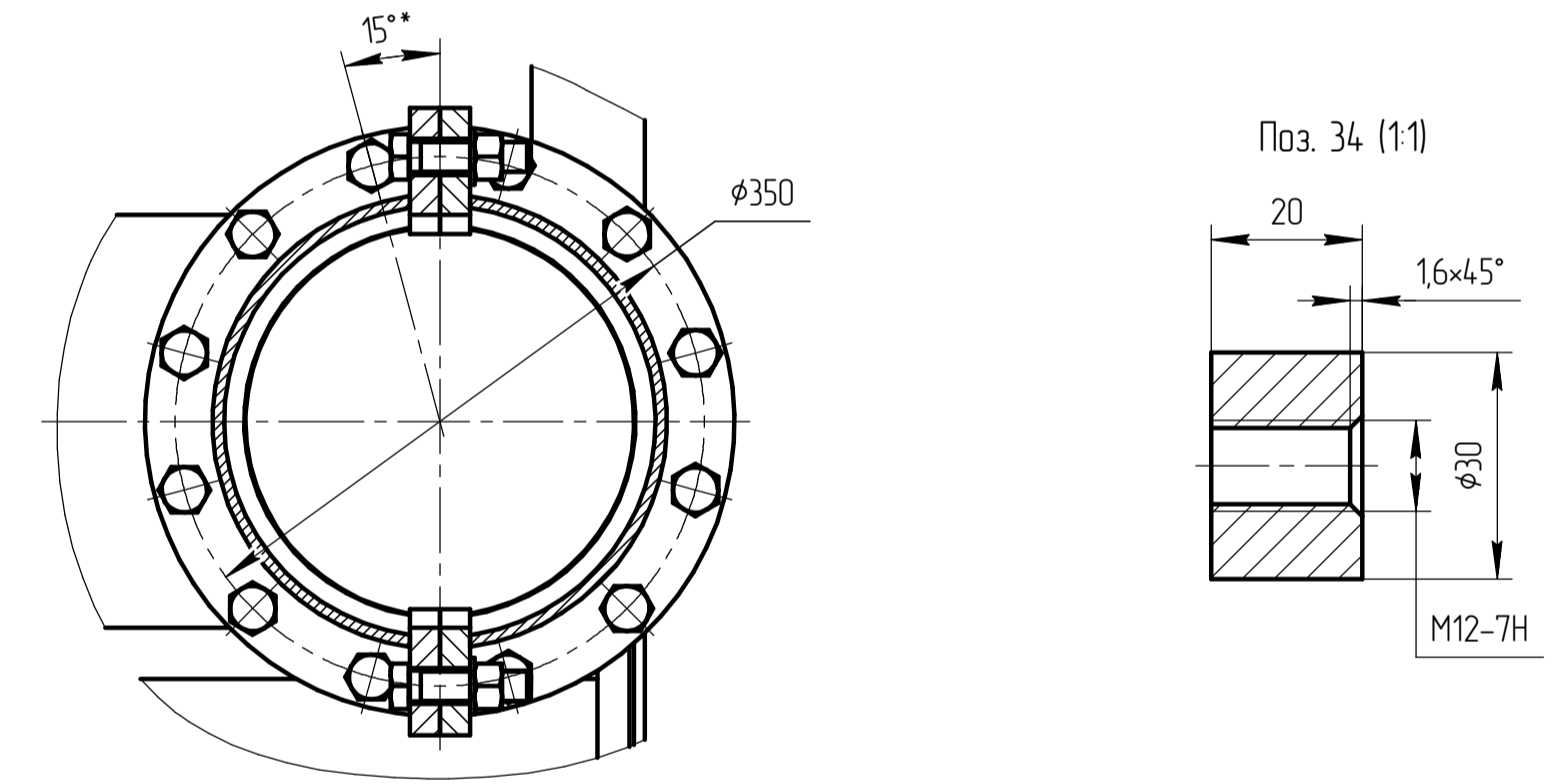

У-У(1:5)(6А)

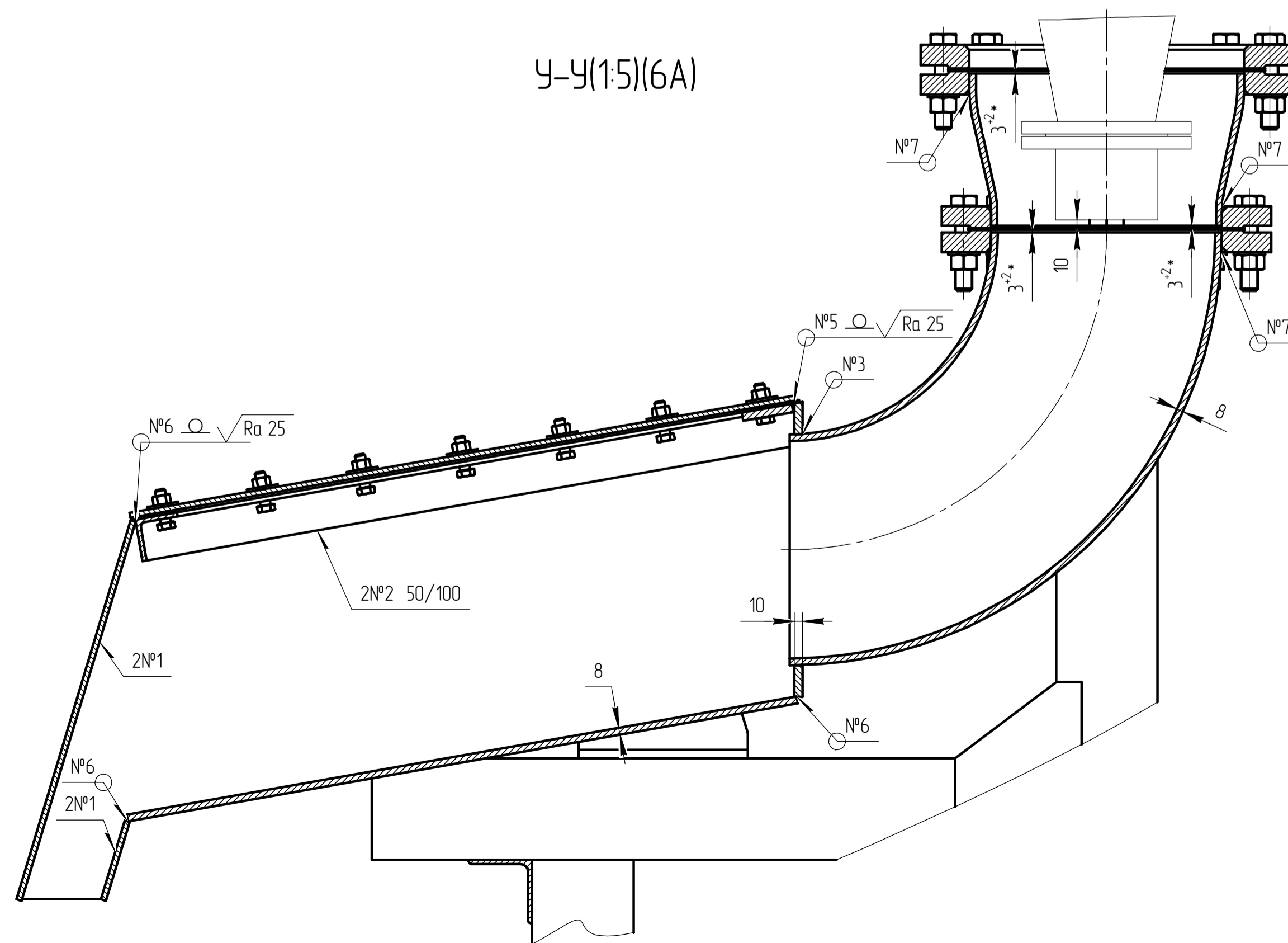

Д-Д(1:5)(7В)

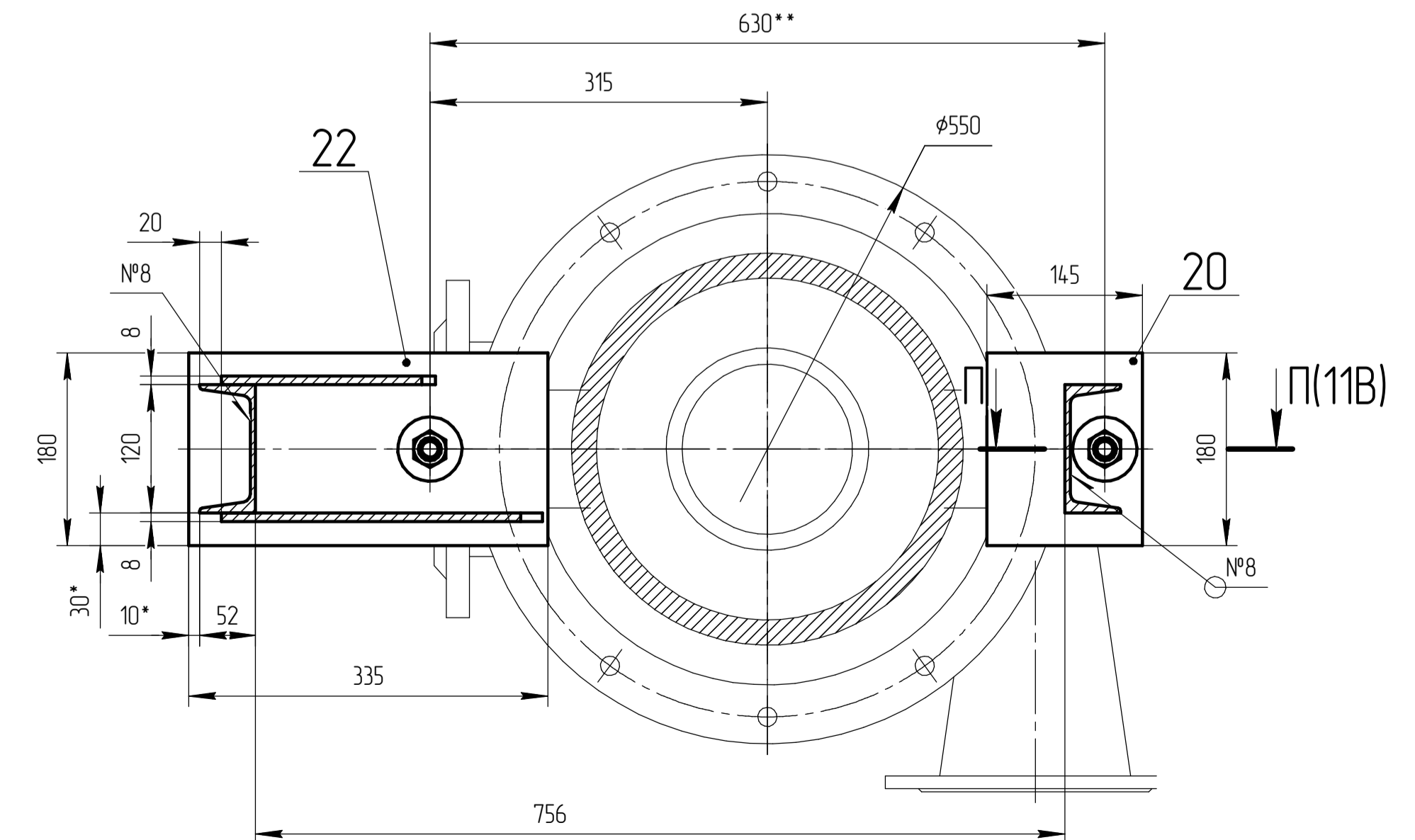

Р-Р(1:5)(5А)

